

STANDARD VERSION

Characteristics (Options not included)

Length	:	7.70	m
Beam	:	3.00	m
Draft keel boat	:	1.60	m
Draft twin keels boat	:	1.20	m
Draft lifting keel boat	:	0.90/1.90	m
Displacement	:	1.750 t	for keel boat
Mainsail	:	25	m ²
Genoa	:	20	m ²
Spinnaker	:	55/70	m ²
Engine	:	- Outboard (options not included in standard price) - Inboard (options not included in standard price)	
Category	:	B	
Rudders	:	2	units
Keel weight for keel boat	:	600	Kg
Keel weight for twin keels boat	:	780	Kg
Keel weight for lifting keel boat	:	NC	Kg
Headroom	:	1.70	m
Category	:	B	
Mast and boom	:	- aluminium	
Asymmetric spinnaker rigging	:	- aluminium	



Design by Pierre Rolland Architect
Build Concept by Marée Haute

3 Keels Versions

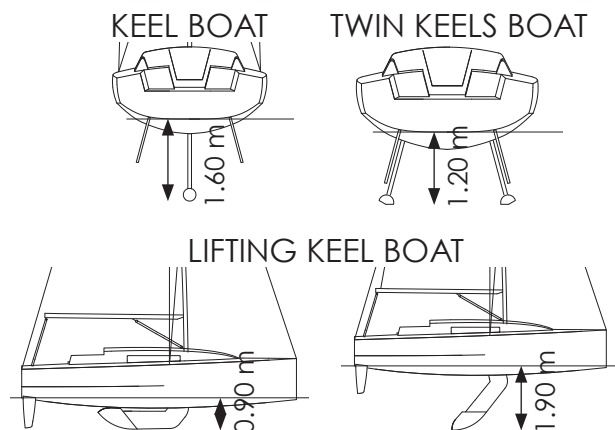

2 interiors layout Versions with 5 berths

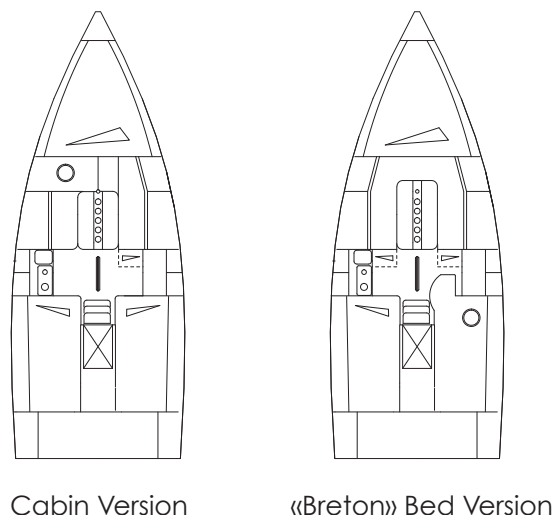

KEEL BOAT - TWIN KEELS BOAT - LIFTING KEEL BOAT

CHANTIER MAREE HAUTE

Route du Phare de Pouldohan - 29910 TRÉGUNC - FINISTÈRE / FRANCE - Tél 00 33 (0)2 98 56 56 03 / Fax 00 33 (0)2 98 60 20 62

E-mail : chantier.mareehaute@orange.fr
Web : www.mareehaute.fr